



INTERCONNECTION FACILITIES STUDY REPORT

GEN-2017-199

Published April 2023

By SPP Generator Interconnections Dept.

REVISION HISTORY

DATE OR VERSION NUMBER	AUTHOR	CHANGE DESCRIPTION
04/13/2023	SPP	Initial draft report issued.

CONTENTS

Revision History	i
Summary	1
Introduction	1
Phase(s) of Interconnection Service	1
Compensation for Amounts Advanced for Network Upgrade(s).....	1
Interconnection Customer Interconnection Facilities	2
Transmission Owner Interconnection Facilities and Non-Shared Network Upgrade(s)	3
Shared Network Upgrade(s)	4
Contingent Network Upgrade(s).....	6
Affected System Upgrade(s)	7
Conclusion.....	8
Appendices	9
A: Transmission Owner’s Interconnection Facilities Study Report and Network Upgrades Report(s)...	10

SUMMARY

INTRODUCTION

This Interconnection Facilities Study (IFS) for Interconnection Request is for a 202 MW generating facility located in Beadle County, SD. The Interconnection Request was studied in the DISIS-2017-002 Impact Study for ERIS. The Interconnection Customer's requested in-service date is December 29, 2026.

The interconnecting Transmission Owner, Basin Electric Power Cooperative (BEPC), performed a detailed IFS at the request of SPP. The full report is included in Appendix A. SPP has determined that full Interconnection Service will be available after the assigned Transmission Owner Interconnection Facilities (TOIF), Non-Shared Network Upgrades, Shared Network Upgrades, Contingent Network Upgrades, and Affected System Upgrades that are required for full interconnection service are completed.

The primary objective of the IFS is to identify necessary Transmission Owner Interconnection Facilities, Network Upgrades, other direct assigned upgrades, cost estimates, and associated upgrade lead times needed to grant the requested Interconnection Service.

PHASE(S) OF INTERCONNECTION SERVICE

It is not expected that Interconnection Service will occur in phases. However, full Interconnection Service will not be available until all Interconnection Facilities and Network Upgrade(s) can be placed in service.

COMPENSATION FOR AMOUNTS ADVANCED FOR NETWORK UPGRADE(S)

FERC Order ER20-1687-000 eliminated the use of Attachment Z2 revenue crediting as an option for compensation. The Incremental Long Term Congestion Right (ILTCR) process will be the sole process to compensate upgrade sponsors as of July 1st, 2020.

INTERCONNECTION CUSTOMER INTERCONNECTION FACILITIES

The Generating Facility is proposed to consist of (64) Power Electronics 3.156 MW inverters for a total generating nameplate capacity of 202 MW.

The Interconnection Customer's Interconnection Facilities to be designed, procured, constructed, installed, maintained, and owned by the Interconnection Customer at its sole expense include:

- 34.5 kV underground cable collection circuits;
- 34.5 kV to 345 kV transformation substation with associated 34.5 kV and 345 kV switchgear;
- One 345/34.5 kV 135/180/225 MVA (ONAN/ONAF/ONAF) step-up transformer to be owned and maintained by the Interconnection Customer at the Interconnection Customer's substation;
- Approx. 20 miles 345 kV line to connect the Interconnection Customer's substation to the Point of Interconnection ("POI") at the 345 kV bus at existing Transmission Owner substation ("Groton 345kV Substation") that is owned and maintained by Transmission Owner;
- All transmission facilities required to connect the Interconnection Customer's substation to the POI;
- Equipment at the Interconnection Customer's substation necessary to maintain a composite power delivery at continuous rated power output at the high-side of the generator substation at a power factor within the range of 95% lagging and 95% leading in accordance with Federal Energy Regulatory Commission (FERC) Order 827. The Interconnection Customer may use inverter manufacturing options for providing reactive power under no/reduced generation conditions. The Interconnection Customer will be required to provide documentation and design specifications demonstrating how the requirements are met; and,
- All necessary relay, protection, control and communication systems required to protect Interconnection Customer's Interconnection Facilities and Generating Facilities and coordinate with Transmission Owner's relay, protection, control and communication systems.

TRANSMISSION OWNER INTERCONNECTION FACILITIES AND NON-SHARED NETWORK UPGRADE(S)

To facilitate interconnection, the interconnecting Transmission Owner will perform work as shown below necessary for the acceptance of the Interconnection Customer’s Interconnection Facilities.

Table 1 and **Table 2** lists the Interconnection Customer’s estimated cost responsibility for Transmission Owner Interconnection Facilities (TOIF) and Non-Shared Network Upgrade(s) and provides an estimated lead time for completion of construction. The estimated lead time begins when the Generator Interconnection Agreement has been fully executed.

Table 1: Transmission Owner Interconnection Facilities (TOIF)

Transmission Owner Interconnection Facilities (TOIF)	Total Cost Estimate (\$)	Allocated Percent (%)	Allocated Cost Estimate (\$)	Estimated Lead Time
<u>Groton 345kV GEN-2017-199 Interconnection (TOIF) (BEPC) (143485):</u> Interconnection upgrades and cost estimates needed to interconnect the following Interconnection Customer facility, GEN-2017-199 (202 MW/Battery), into the Point of Interconnection (POI) at Groton 345kV	\$887,359	100%	\$887,359	26 Months
Total	\$887,359		\$887,359	

Table 2: Non-Shared Network Upgrade(s)

Non-Shared Network Upgrades Description	ILTCR	Total Cost Estimate (\$)	Allocated Percent (%)	Allocated Cost Estimate (\$)	Estimated Lead Time
<u>NA</u>	NA	NA	NA	NA	NA
Total		NA		NA	

SHARED NETWORK UPGRADE(S)

The Interconnection Customer’s share of costs for Shared Network Upgrades is estimated in **Table 3** below.

Table 3: Interconnection Customer Shared Network Upgrade(s)

Shared Network Upgrades Description	ILTCR	Total Cost Estimate (\$)	Allocated Percent (%)	Allocated Cost Estimate (\$)	Estimated Lead Time
<u>Groton 345-115 kV Second Transformer Build (DISIS-2017-002)(156423):</u> Install a new 345/115 kV Transformer at Groton substation	Eligible	\$16,850,884	38.99%	\$6,569,670.54	42 Months
<u>Groton 345kV Interconnection Expansion (DISIS-2017-002)(143484):</u> Expand the Groton 345kV substation to accommodate the interconnection of GEN-2017-199 and GEN-2017-200	Ineligible	\$1,948,835	40.08%	\$781,080.69	26 Months
<u>Groton BE8 to Groton South 115 kV Second Line Build (DISIS-2017-002) (BEPC)(156415):</u> Build a new 0.1 mile 115kV line from Groton BE8 to Groton South	Eligible	\$2,176,630	38.82%	\$844,968.21	42 Months
<u>Groton BE8 to Groton South 115 kV Second Line Build (DISIS-2017-002) (WAPA)(156469):</u> Build a new 0.1 mile 115kV line from Groton South to Groton BE7	Eligible	\$2,800,000	38.82%	\$1,086,960.57	30 Months
<u>Groton to Aberdeen 115 kV Rebuild (DISIS-2017-002)(156434):</u> Rebuild the Groton to Aberdeen 115 kV 25.75 mile line to achieve a min winter emergency rating of 178 MVA and a min summer emergency rating of 195 MVA	Eligible	\$18,304,130	41.71%	\$7,634,982.52	1 Month

<p><u>Groton to Bristol 115 kV Rebuild (DISIS-2017-002)(156435):</u> Rebuild the Groton to Bristol 115 kV 21.3 mile line to achieve a min winter emergency rating of 158 MVA and a min summer emergency rating of 177 MVA</p>	Eligible	\$14,960,000	40.38%	\$6,040,856.62	36 Months
<p><u>Groton to Groton South 115 kV Terminal Equipment Upgrades (DISIS-2017-002)(156416):</u> Upgrade terminal equipment at the Groton and Groton South 115 kV substations to increase the minimum rating to 399 MVA</p>	Eligible	\$2,891,177	41.15%	\$1,189,602.67	36 Months
<p><u>Summit to Bristol 115 kV Rebuild (DISIS-2017-002)(156449):</u> Rebuild the Summit to Bristol 115 kV 32.56 mile line to achieve a min winter emergency rating of 151 MVA and a min summer emergency rating of 174 MVA</p>	Eligible	\$29,565,000	40.38%	\$11,938,364.04	36 Months
<p>Total</p>		\$89,496,656		\$36,086,485.86	

All studies have been conducted assuming that higher-queued Interconnection Request(s) and the associated Network Upgrade(s) will be placed into service. If higher-queued Interconnection Request(s) withdraw from the queue, suspend or terminate service, the Interconnection Customer's share of costs may be revised. Restudies, conducted at the customer's expense, will determine the Interconnection Customer's revised allocation of Shared Network Upgrades.

CONTINGENT NETWORK UPGRADE(S)

Certain Contingent Network Upgrades are **currently not the cost responsibility** of the Interconnection Customer but will be required for full Interconnection Service.

Table 4: Interconnection Customer Contingent Network Upgrade(s)

Contingent Network Upgrade(s) Description	Current Cost Assignment	Estimated In-Service Date
<u>NA</u>	<u>NA</u>	<u>NA</u>

Depending upon the status of higher- or equally-queued customers, the Interconnection Request’s in-service date is at risk of being delayed or Interconnection Service is at risk of being reduced until the in-service date of these Contingent Network Upgrades.

AFFECTED SYSTEM UPGRADE(S)

To facilitate interconnection, the Affected System Transmission Owner will be required to perform the facilities study work as shown below necessary for the acceptance of the Interconnection Customer’s Interconnection Facilities. **Table 5** displays the current impact study costs provided by either MISO or AECI as part of the Affected System Impact review. The Affected System facilities study could provide revised costs and will provide each Interconnection Customer’s allocation responsibilities for the upgrades.

Table 5: Interconnection Customer Affected System Upgrade(s)

Affected System Upgrades Description	Total Cost Estimate (\$)	Allocated Percent (%)	Allocated Cost Estimate (\$)
<u>AECI; Rebuild 5.58-mile-long Conway to Phillipsburg 69 kV line with 336.4 ACSR rated at 100C</u>	\$5,040,000	5.13%	\$258,522
Total	\$5,040,000		\$258,522

CONCLUSION

After all Interconnection Facilities and Network Upgrades have been placed into service, Interconnection Service for MW can be granted. Full Interconnection Service will be delayed until the TOIF, Non-Shared NU, Shared NU, Contingent NU, Affected System Upgrades that are required for full interconnection service are completed. The Interconnection Customer’s estimated cost responsibility for full interconnection service is summarized in the table below.

Table 6: Cost Summary

Description	Allocated Cost Estimate
Transmission Owner Interconnection Facilities Upgrade(s)	\$887,359
Non-Shared Network Upgrade(s)	\$0
Shared Network Upgrade(s)	\$36,086,485.86
Affected System Upgrade(s)	\$258,522
Total	\$37,232,366.86

Use the following link for Quarterly Updates on upgrades from this report: <https://spp.org/spp-documents-filings/?id=18641>

A draft Generator Interconnection Agreement will be provided to the Interconnection Customer consistent with the final results of this IFS report. The Transmission Owner and Interconnection Customer will have 60 days to negotiate the terms of the GIA consistent with the SPP Open Access Transmission Tariff (OATT).

APPENDICES

**A: TRANSMISSION OWNER'S INTERCONNECTION FACILITIES STUDY
REPORT AND NETWORK UPGRADES REPORT(S)**

See next page for the Transmission Owner's Interconnection Facilities Study Report and Network Upgrades Report(s).

Network Upgrade Facilities Study Report

*Southwest Power Pool, Inc. DISIS-2017-002
Groton South 115-kV Bay Addition
(Groton South-Basin Groton 115-kV Tie-line)*



**Western Area
Power Administration**
Upper Great Plains Region

April 2023





1.0 Background:

The Western Area Power Administration Upper Great Plains Region (WAPA-UGP¹) received a request from the Southwest Power Pool Inc. (SPP) for a Network Upgrade Facilities Study in accordance with the SPP Open Access Transmission Tariff (Tariff). Multiple Interconnection requests representing approximately 900 MW of generation additions on the Groton 345-kV and Logan 230-kV buses were submitted. These Generation Interconnections were included in the SPP DISIS-2017-002 study which identified the requirement to construct a new 115-kV line from Basin Electric Power Cooperative's (BEPC) Groton Substation to WAPA-UGP'S Groton South Switching Station. BEPC is responsible to construct the 115-kV transmission line. WAPA-UGP is the owner of the Groton South 115-kV Switching Station and will be responsible for additions to accommodate termination of the new line.

WAPA-UGP is not the Transmission Owner of the Points of Interconnection (POI). The facility additions at WAPA-UGP's Groton South 115-kV Switching Station are considered a "Network Upgrade constructed by other transmission owning entity" and will require a Notification to Construct from SPP.

This Interconnection Facilities Study does not address transmission service or any delivery component of transmission service.

2.0 Study Requirements:

This Facilities Study includes an evaluation of the following:

- 2.1** Develop/compile cost estimates for all WAPA-UGP labor, overheads, facility additions, modifications, etc. to accommodate the requested Network Upgrade.
- 2.2** Review and document any other interconnection/control area requirements. Document these additional requirements (such as indication/metering, monitoring, control, relaying) and include these in the cost estimate.
- 2.3** Develop an overall time schedule for completion of the necessary addition/modifications.

3.0 Study Results:

WAPA-UGP performed the following tasks to evaluate the additions to the system to accommodate the 115-kV additions and outlined in Section 2.0 above:

- 3.1 Required Facility Additions by WAPA-UGP:** The evaluation of facilities to accommodate the addition of a BEPC Groton-WAPA-UGP Groton South 115-kV Transmission Line identified the following requirements:

¹ WAPA-UGP is also referred to as "Western-UGP" in the SPP Tariff.



- Addition of a new 115-kV bay at Groton South Switching Station
- Modify relay settings to accommodate BEPC's reconfiguration of line terminations at Groton South Switching Station

Construction of the bay addition at Groton South Switching Station will require two (2) 115-kV power circuit breakers, four (4) 115-kV disconnect switches, instrument transformers, associated control and protection equipment, high-voltage bus, a transmission line take-off-structure, and conductor. The line bay will require a minimum rating of 480 MVA.

WAPA-UGP's estimated cost for labor, overhead, equipment additions, modifications, and other miscellaneous costs are outlined in Attachment A. The total cost for the Network Upgrade is estimated to be \$2,800,000. The interconnection customer is responsible for the entire cost of the project.

3.2 Contractual Agreements: Pursuant to the SPP Tariff, SPP and the POI TO will need to execute a Generator Interconnection Agreement (GIA) (or initially an Interim GIA, if applicable, with a subsequent execution of a GIA) with Interconnection Customer for the interconnection of the Generating Facility. The GIA will address specific funding requirements and provide an advanced payment schedule for facility additions and upgrades to address WAPA-UGP's requirements. The GIA, which discusses the construction and interconnection aspects of this project, will need to be developed and offered by SPP, pursuant to their obligations and procedures under the SPP Tariff, and forwarded to the Interconnection Customer for review and signature. A schedule for payment(s) based on design, procurement, and construction activities will be included in the GIA consistent with the SPP Tariff provisions. The interconnection customer will be responsible for the actual costs for additions and modifications at WAPA-UGP'S Groton South Switching Station, and WAPA-UGP will require advance funding to proceed with the project. Upon completion of the work WAPA-UGP will own, operate, and maintain the modifications and improvements to WAPA-UGP's Groton South Switching Station.

3.3 Interconnection/Control Area Requirements: N/A

3.4 Schedule: Attachment A outline's WAPA-UGP's estimated schedule for planning, design and construction of the facilities required to accommodate Network Upgrades. WAPA-UGP anticipates the 115-kV bay addition at Groton South Switching Station will be completed by October 1, 2026. This schedule is based on the GIA (or Interim GIA) being executed prior to October 1, 2023, and issuance of the NEPA Finding of No Significant Impact or Record of Decision by January 1, 2025. The schedule is also dependent on outage availability.

4.0 Environmental Review:

WAPA-UGP is a federal agency under the U.S. Department of Energy and is subject to the National Environmental Policy Act (NEPA), 42 U.S.C §4321, et seq., as amended. WAPA-UGP anticipates an Environmental Assessment level of NEPA review will be required for the construction of the BEPC



Groton-WAPA-UGP Groton South 115-kV Transmission Line and associated terminal additions. The Environmental Review is performed at the Interconnection Customers' expense, and those costs are considered direct assigned costs and are ineligible for credits under the SPP Tariff. Until the appropriate NEPA review is completed (issuance of a FONSI, ROD, or other), no construction activities relating to the TO's Network Upgrades may commence.

5.0 Facilities Study Cost:

WAPA-UGP will audit the Interconnection Facilities Study costs and provide a summary of these costs to SPP.



ATTACHMENT A

GROTON SOUTH 115-KV BAY ADDITION

PROJECT ACTIVITY	ESTIMATED START DATE	ESTIMATED COST, MILESTONE PAYMENT DUE
Preconstruction activities – planning, project management, etc.	Upon receipt of funds following execution of the GIA.	\$80,000
Provide staff and other resources to engineer, design, and plan construction	Upon receipt of funds following execution of the GIA.	\$225,000
Procure material and parts necessary to construct	Upon receipt of funds following execution of the GIA.	\$620,000
Development, Solicitation, and Award of Construction Contract(s)	February 1, 2025	\$1,190,000
WAPA-UGP Construction Supervision and Administration	February 1, 2025	\$160,000
Commissioning, Energization, and construction supervision	March 1, 2026	\$235,000
In-Service (Estimated Completion Date)	December 1, 2026*	
TOTAL ESTIMATED COSTS		\$2,800,000**

*Based on GIA execution and receipt of funds by October 1, 2023.

**Based on WAPA-UPG’S understanding of the SPP Tariff, these Network Upgrades are considered and would be evaluated under Attachment Z2 of the SPP Tariff as Non-Capacity Network Upgrades.



Network Upgrade Facilities Study Report

*Southwest Power Pool, Inc. DISIS-2017-002
Groton-Bristol 115-kV
Transmission Line Rebuild*



**Western Area
Power Administration**
Upper Great Plains Region

April 2023





1.0 Background:

The Western Area Power Administration Upper Great Plains Region (WAPA-UGP¹) received a request from the Southwest Power Pool Inc. (SPP) for a Network Upgrade Facilities Study in accordance with the SPP Open Access Transmission Tariff (Tariff). Two Generation Interconnection requests representing 504 MW of generation additions on the Groton 345-kV bus were submitted. These Generation Interconnections were included in the SPP DISIS-2017-002 study which identified the need to increase the rating of WAPA-UGP's Groton-Bristol 115-kV Transmission Line. WAPA-UGP is not the Transmission Owner (TO) of the Points of Interconnection (POI) at Bristol Substation. The facility upgrades to achieve a higher rating on WAPA-UGP's Groton-Bristol 115-kV Transmission is considered a "Network Upgrade constructed by other transmission owning entity" and will require a Notification to Construct from SPP.

This Interconnection Facilities Study does not address transmission service or any delivery component of transmission service.

2.0 Study Requirements:

This Facilities Study includes an evaluation of the following:

- 2.1** Develop/compile cost estimates for all WAPA-UGP labor, overheads, facility additions, modifications, etc. to accommodate the requested Network Upgrade.
- 2.2** Review and document any other interconnection/control area requirements. Document these additional requirements (such as indication/metering, monitoring, control, relaying) and include these in the cost estimate.
- 2.3** Develop an overall time schedule for completion of the necessary addition/modifications.

3.0 Study Results:

WAPA-UGP performed the following tasks to evaluate the modifications to the system to accommodate the line rating increase request as studied and outlined in Section 2.0 above:

3.1 Required Facility Upgrades by WAPA-UGP: The evaluation of facilities to accommodate the rating increase on WAPA-UGP's Groton-Bristol 115-kV Transmission Line is identified the following requirements:

- Rebuild the 21.3-mile Groton-Bristol 115-kV Transmission Line
- Replace existing conductor at Groton Substation in Bay 5 from the Take-off-Structure to the rigid bus
- Replace jumpers at Groton Substation for breakers 462 and 562

¹ WAPA-UGP is also referred to as "Western-UGP" in the SPP Tariff.



The line rebuild will require new structures and conductor along the existing right-of-way to achieve a required rating of 174 MVA.

WAPA-UGP is not the TO of the Bristol Substation terminal equipment and bus.

WAPA-UGP's estimated cost for labor, overhead, materials, and other miscellaneous costs to rebuild WAPA-UGP'S Groton-Bristol 115-kV Transmission Line and perform upgrades at Groton Substation is outlined in Attachment A. The total cost for the Network Upgrade is estimated to be \$14,960,000. The Interconnection Customer is responsible for the entire cost of the project.

3.2 Contractual Agreements: Pursuant to the SPP Tariff, SPP and the POI TO will need to execute a Generator Interconnection Agreement (GIA) (or initially an Interim GIA, if applicable, with a subsequent execution of a GIA) with Interconnection Customer for the interconnection of the Generating Facility. The GIA will address specific funding requirements and provide an advanced payment schedule for facility additions and upgrades to address WAPA-UGP's requirements. The GIA, which discusses the construction and interconnection aspects of this project, will need to be developed and offered by SPP, pursuant to their obligations and procedures under the SPP Tariff, and forwarded to the Interconnection Customer for review and signature. A schedule for payment(s) based on design, procurement, and construction activities will be included in the GIA consistent with the SPP Tariff provisions. The Interconnection Customer will be responsible for the actual costs associated with the upgrades to WAPA-UGP'S Groton-Bristol 115-kV Transmission Line and associated terminals, and WAPA-UGP will require advance funding to proceed with the project. Upon completion of the work WAPA-UGP will own, operate, and maintain the modifications and improvements to WAPA-UGP's transmission line.

3.3 Interconnection/Control Area Requirements: N/A

3.4 Schedule: Attachment A outline's WAPA-UGP's estimated schedule for planning, design and construction of the facilities required to accommodate the Interconnections Customer's Request. WAPA-UGP anticipates the rebuild of the Groton-Bristol 115-kV Transmission Line would be completed by December 1, 2026. This schedule is based on the GIA (or Interim GIA) being executed prior to July 1, 2023, and issuance of the NEPA Finding of No Significant Impact or Record of Decision by January 1, 2025. The schedule is also dependent on outage availability.

4.0 Environmental Review:

WAPA-UGP is a federal agency under the U.S. Department of Energy and is subject to the National Environmental Policy Act (NEPA), 42 U.S.C §4321, et seq., as amended. WAPA-UGP anticipates an Environmental Assessment level of NEPA review will be required for the rebuild WAPA-UGP'S Groton-Bristol 115-kV Transmission Line. The Environmental Review is performed at the Interconnection Customer's expense, and those costs are considered direct assigned costs and are ineligible for credits under the SPP Tariff. A separate Environmental Review agreement will need to be executed between the Interconnection Customers and WAPA-UGP. Until the appropriate NEPA review is completed



(issuance of a FONSI, ROD, or other), no construction activities relating to Transmission Owner's Network Upgrades may commence.

5.0 Facilities Study Cost:

WAPA-UGP will audit the Interconnection Facilities Study costs and provide a summary of these costs to SPP.



ATTACHMENT A

REBUILD WAPA-UGP'S GROTON-BRISTOL 115-KV TRANSMISSION LINE

PROJECT ACTIVITY	ESTIMATED START DATE	ESTIMATED COST, MILESTONE PAYMENT DUE
Preconstruction activities – planning, project management, etc.	Upon receipt of funds following execution of the GIA.	\$250,000
Provide staff and other resources to engineer, design, and plan construction	Upon receipt of funds following execution of the GIA.	\$355,000
Procure material and parts necessary to construct	October 15, 2024	\$2,500,000
Development, Solicitation, & Award of Construction Contract(s)	October 15, 2024	\$11,255,000
Commissioning, Energization, and construction supervision	January 15, 2026	\$600,000
In-Service (Estimated Completion Date)	December 1, 2026*	
TOTAL ESTIMATED COSTS		\$14,960,000**

*Based on GIA execution and receipt of funds by July 1, 2023.

**Based on WAPA-UGP'S understanding of the SPP Tariff, these Network Upgrades are considered and would be evaluated under Attachment Z2 of the SPP Tariff as Non-Capacity Network Upgrades.



Network Upgrade Facilities Study Report

*Southwest Power Pool, Inc. DISIS-2017-002
Summit-Bristol 115-kV
Transmission Line Rebuild*



**Western Area
Power Administration**
Upper Great Plains Region

April 2023





1.0 Background:

The Western Area Power Administration Upper Great Plains Region (WAPA-UGP¹) received a request from the Southwest Power Pool Inc. (SPP) for a Network Upgrade Facilities Study in accordance with the SPP Open Access Transmission Tariff (Tariff). Two Generation Interconnection requests representing 504 MW of generation additions on the Groton 345-kV bus were submitted. These Generation Interconnections were included in the SPP DISIS-2017-002 study which identified the need to increase the rating of WAPA-UGP's Summit-Bristol 115-kV Transmission Line. WAPA-UGP is not the Transmission Owner (TO) of the Points of Interconnection (POI). The facility upgrades to achieve a higher rating on WAPA-UGP's Summit-Bristol 115-kV Transmission is considered a "Network Upgrade constructed by other transmission owning entity" and will require a Notification to Construct from SPP.

This Interconnection Facilities Study does not address transmission service or any delivery component of transmission service.

2.0 Study Requirements:

This Facilities Study includes an evaluation of the following:

- 2.1** Develop/compile cost estimates for all WAPA-UGP labor, overheads, facility additions, modifications, etc. to accommodate the requested Network Upgrade.
- 2.2** Review and document any other interconnection/control area requirements. Document these additional requirements (such as indication/metering, monitoring, control, relaying) and include these in the cost estimate.
- 2.3** Develop an overall time schedule for completion of the necessary addition/modifications.

3.0 Study Results:

WAPA-UGP performed the following tasks to evaluate the modifications to the system to accommodate the line rating increase request as studied and outlined in Section 2.0 above:

3.1 Required Facility Upgrades by WAPA-UGP: The evaluation of facilities to accommodate the rating increase on WAPA-UGP's Summit-Bristol 115-kV Transmission Line is identified the following requirements:

- Rebuild the 21.3-mile Summit-Bristol 115-kV Transmission Line
- Replace existing conductor at Summit Substation in Bay 4 from the Take-Off-Structure to the rigid bus
- Replace jumpers to breaker 562 at Summit Substation

¹ WAPA-UGP is also referred to as "Western-UGP" in the SPP Tariff.



The line rebuild will require new structures and conductor along the existing and newly acquired right-of-way to achieve a required rating of 174 MVA.

WAPA-UGP is not the TO of the Bristol Substation terminal equipment and bus.

WAPA-UGP's estimated cost for labor, overhead, materials, and other miscellaneous costs to rebuild WAPA-UGP'S Summit-Bristol 115-kV Transmission Line and perform upgrades at Summit Substation is outlined in Attachment A. The total cost for the Network Upgrade is estimated to be \$29,565,000. The Interconnection Customer is responsible for the entire cost of the project.

3.2 Contractual Agreements: Pursuant to the SPP Tariff, SPP and the POI TO will need to execute a Generator Interconnection Agreement (GIA) (or initially an Interim GIA, if applicable, with a subsequent execution of a GIA) with Interconnection Customer for the interconnection of the Generating Facility. The GIA will address specific funding requirements and provide an advanced payment schedule for facility additions and upgrades to address WAPA-UGP's requirements. The GIA, which discusses the construction and interconnection aspects of this project, will need to be developed and offered by SPP, pursuant to their obligations and procedures under the SPP Tariff, and forwarded to the Interconnection Customer for review and signature. A schedule for payment(s) based on design, procurement, and construction activities will be included in the GIA consistent with the SPP Tariff provisions. The Interconnection Customer will be responsible for the actual costs associated with the upgrades to WAPA-UGP'S Summit-Bristol 115-kV Transmission Line and associated terminals, and WAPA-UGP will require advance funding to proceed with the project. Upon completion of the work WAPA-UGP will own, operate, and maintain the modifications and improvements to WAPA-UGP's transmission line.

3.3 Interconnection/Control Area Requirements: N/A

3.4 Schedule: Attachment A outline's WAPA-UGP's estimated schedule for planning, design, and construction of the facilities required to accommodate the Interconnections Customer's Request. WAPA-UGP anticipates the rebuild of the Summit-Bristol 115-kV Transmission Line would be completed by December 1, 2027. This schedule is based on the GIA (or Interim GIA) being executed prior to July 1, 2023, and issuance of the NEPA Finding of No Significant Impact or Record of Decision by January 1, 2026. The schedule is also dependent on outage availability.

4.0 Environmental Review:

WAPA-UGP is a federal agency under the U.S. Department of Energy and is subject to the National Environmental Policy Act (NEPA), 42 U.S.C §4321, et seq., as amended. WAPA-UGP anticipates an Environmental Assessment level of NEPA review will be required for the rebuild WAPA-UGP'S Summit-Bristol 115-kV Transmission Line. The Environmental Review is performed at the Interconnection Customer's expense, and those costs are considered direct assigned costs and are ineligible for credits under the SPP Tariff. A separate Environmental Review agreement will need to be executed between the Interconnection Customers and WAPA-UGP. Until the appropriate NEPA



review is completed (issuance of a FONSI, ROD, or other), no construction activities relating to TO's Network Upgrades may commence.

5.0 Facilities Study Cost:

WAPA-UGP will audit the Interconnection Facilities Study costs and provide a summary of these costs to SPP.



ATTACHMENT A

REBUILD WAPA-UGP'S SUMMIT-BRISTOL 115-KV TRANSMISSION LINE

PROJECT ACTIVITY	ESTIMATED START DATE	ESTIMATED COST, MILESTONE PAYMENT DUE
Preconstruction activities – planning, project management, etc.	Upon receipt of funds following execution of the GIA.	\$260,000
Provide staff and other resources to engineer, design, and plan construction	Upon receipt of funds following execution of the GIA.	\$350,000
Procure material and parts necessary to construct	October 15, 2025	\$5,200,000
Development, Solicitation, & Award of Construction Contract(s)	October 15, 2025	\$23,135,000
Commissioning, Energization, and construction supervision	January 15, 2027	\$620,000
In-Service (Estimated Completion Date)	December 1, 2027*	
TOTAL ESTIMATED COSTS		\$29,565,000**

*Based on GIA execution and receipt of funds by July 1, 2023.

**Based on WAPA-UGP'S understanding of the SPP Tariff, these Network Upgrades are considered and would be evaluated under Attachment Z2 of the SPP Tariff as Non-Capacity Network Upgrades.



Basin Electric Power Cooperative Interconnection Facilities Study GEN-2017-199/GEN-2017-200

1. Background:

- 1.1 Per SPP Generation Interconnection Process¹, Basin Electric Power Cooperative (Basin Electric) received a request to perform an Interconnection Facility Study Analysis for the following Interconnection Requests:

Upgrade Type	UID	Upgrade Name
Interconnection	143484	Groton 345kV Interconnection Expansion (DISIS-2017-002)
Interconnection	143485	Groton 345kV GEN-2017-199 Interconnection (TOIF) (BEPC)
Interconnection	143487	Groton 345kV GEN-2017-200 Interconnection (TOIF) (BEPC)

¹ SPP Tariff Attachment V Generator Interconnection Procedures (GIP) Section 8.11

2. Study Requirements:

Basin Electric has performed this Interconnection Facility Study Analysis in accordance with SPP Tariff Attachment V, Generator Interconnection Procedures (GIP) Section 8.11 for the Interconnection Request(s) as described in Section 1.

2.1. The Interconnection Facility Study Analysis includes an evaluation of the following:

- 2.1.1. Perform/develop a substation layout, perform a preliminary bus design, determine all electrical equipment requirements, and if required determine a suitable site location to accommodate the Request. Develop/compile cost estimates for all Basin Electric labor, overheads, equipment additions, modifications, etc. to accommodate the generator interconnection.
- 2.1.2. Develop an overall construction schedule for completion of the necessary additions and/or modifications.
- 2.1.3. Point Of Change of Ownership. For the purposes of this Study Analysis, the Point of Change of Ownership location is defined as the take-off structure(s) at the Basin Electric Substation/Switching Station where the Interconnection Customer's transmission line(s) connects to the take-off structure(s). Interconnection Customer will furnish and install the conductor jumper and insulator assembly to the take-off structure(s).
- 2.1.4. Other Interconnection/Metering Requirements. Basic indication, metering, monitoring, control, and relaying requirements due to a generator interconnection are included in the cost estimate. Basin Electric's generation metering requirements, as an SPP Transmission Owner, must be met. A list of specific needs will be provided by Basin Electric once design has progressed.

3. Study Results for GEN-2017-199/GEN-2017-200:

3.1. The following results document the analysis of the required facilities for this Interconnection Request as outlined in Section 1 for a new 345 kV line terminal at the Groton 345 kV Substation. Basin Electric has determined that the following additions and improvements are required to maintain a safe and reliable interconnection to Basin Electric's transmission system.

3.2 Substation/Switchyard

A 345 kV terminal addition will be built to accommodate the new generation resource interconnection. This terminal will be added to the existing ring bus substation. Reference Figures A1 and A2. All equipment will follow Basin Electric's internal design standards for minimum BIL, ampacity, and fault capabilities.

The associated work for the new 345 kV line terminal includes the following major additions:

- (1) 345 kV Breaker
- (2) 345 kV Breaker Disconnect Switches
- (1) Set of Line Potential Transformers
- (1) Set of Current Transformers
- (1) Set of Line Surge Arrestors

There are costs estimated for protective relay setting and revenue metering review to support GEN-2017-200.

3.3 Environmental Requirements

Compliance with all applicable federal, state and local regulations will be strictly adhered to. Additionally, all applicable and required permits and approvals will be obtained prior to construction. For the purposes of this Study, it is anticipated that this new 345 kV line terminal will require incidental minor local permitting.

3.4 Cost Estimate

GEN-2017-199 Estimated Costs UID 143484 Non Shared Network Upgrades	Current Year \$
Line Costs	
Engineering Labor	\$0
Construction Labor	\$0
Reactive Compensation (Labor & Materials)	\$0
Material	\$0
Right of Way	\$0
Line Sub Total	\$0
Station Costs	
Engineering Labor	\$425,720
Construction Labor	\$469,665
Site Property Rights	\$0
Reactive Compensation	\$0
Material	\$499,885
Right of Way	\$0
Station Sub Total	\$1,395,270
AFUDC	\$0
Contingency	\$553,565
Non - Shared Network Upgrades total	\$1,948,835

GEN-2017-199 UID 143485 Transmission Owner Interconnect Facilities	Current Year \$
Line Costs	
Engineering Labor	\$0
Construction Labor	\$0
Reactive Compensation (Labor & Materials)	\$0
Material	\$0
Right of Way	\$0
Line Sub Total	\$0
Station Costs	
Engineering Labor	\$100,000
Construction Labor	\$170,071
Site Property Rights	\$0
Reactive Compensation	\$0
Material	\$365,235
Right of Way	\$0
Station Sub Total	\$635,306
AFUDC	\$0
Contingency	\$252,053
TOIF Subtotal	\$887,359

Total Interconnection Cost	\$2,836,194
-----------------------------------	--------------------

GEN-2017-200 UID 143487 Transmission Owner Interconnect Facilities	Current Year \$
Line Costs	
Engineering Labor	\$0
Construction Labor	\$0
Reactive Compensation (Labor & Materials)	\$0
Material	\$0
Right of Way	\$0
Line Sub Total	\$0
Station Costs	
Engineering Labor	\$100,000
Construction Labor	\$0
Site Property Rights	\$0
Reactive Compensation	\$0
Material	\$0
Right of Way	\$0
Station Sub Total	\$100,000
AFUDC	\$0
Contingency	\$0
TOIF Subtotal	\$100,000

Total Interconnection Cost	\$100,000
-----------------------------------	------------------

3.5 Construction Schedule

The preliminary project schedule provided is for planning level purposes only and will be adjusted with additional project definition. If it is determined that NEPA and/or ROW condemnation is required, 12-18 months will be added to the In-Service date.

Activity	Duration	Estimated Start	Estimated Finish
Executed GIA-Notice To Proceed Letter	--	Month 0	--
Project Planning	1 Month	Month 0	Month 1
Engineering Design	6-8 Months	Month 1	Month 9
Equipment Procurement	2-20 Months	Month 2	Month 20
Advertise and Award Construction Contracts	2-3 Months	Month 15	Month 18
Construction	4 Months	Month 20	Month 25
Energize and In-Service Date	1 Month	Month 25	Month 26

Figure A1: Proposed Switching Diagram

FIGURE A1
GEN-2017-199/GEN-2017-200

LEGEND:

- EXISTING EQUIPMENT
- NON SHARED NETWORK UPGRADES
- SHARED NETWORK UPGRADES
- TRANSMISSION OWNERS INTERCONNECTION FACILITIES
- INTERCONNECTION CUSTOMER INTERCONNECTION FACILITIES
- FUTURE

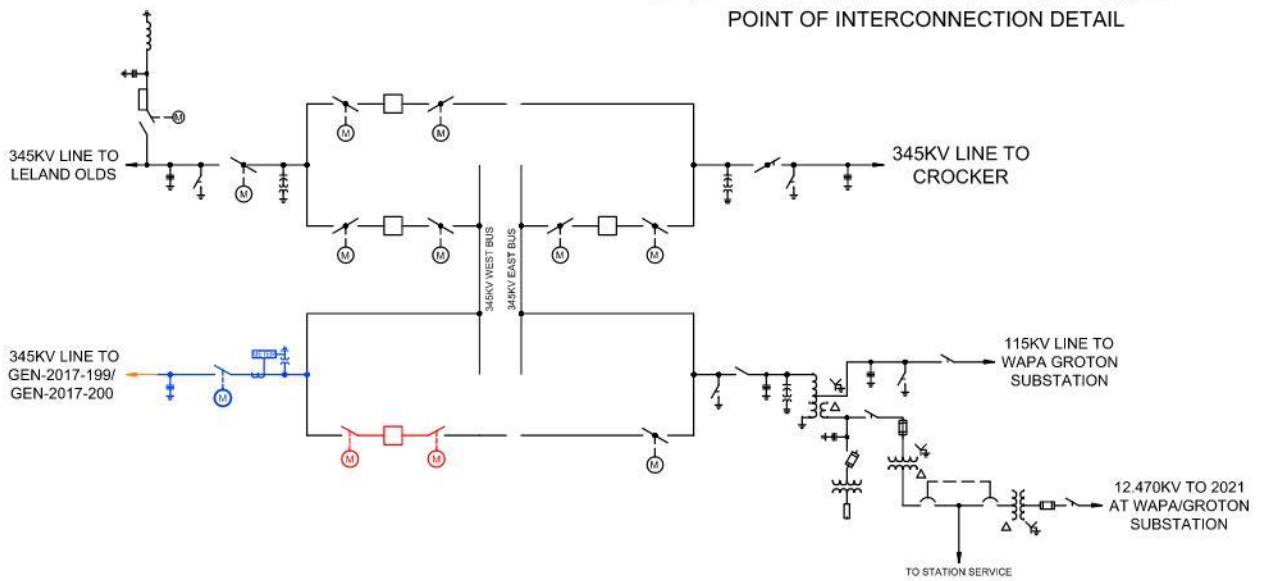
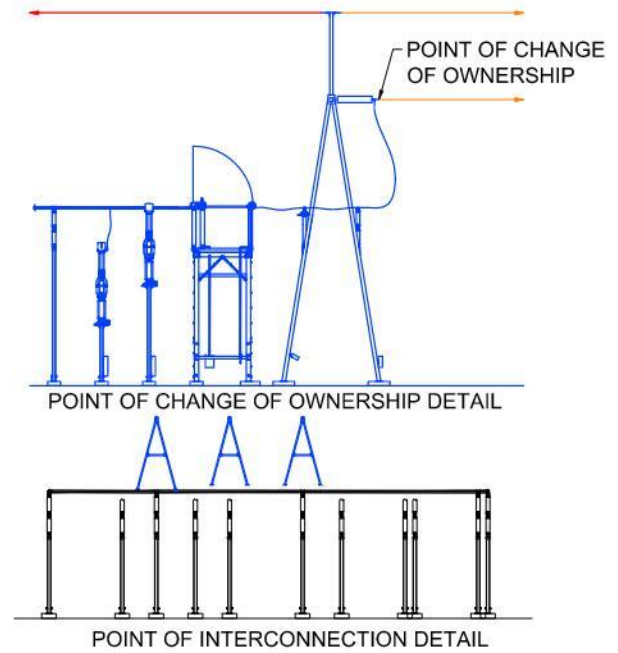
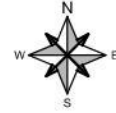
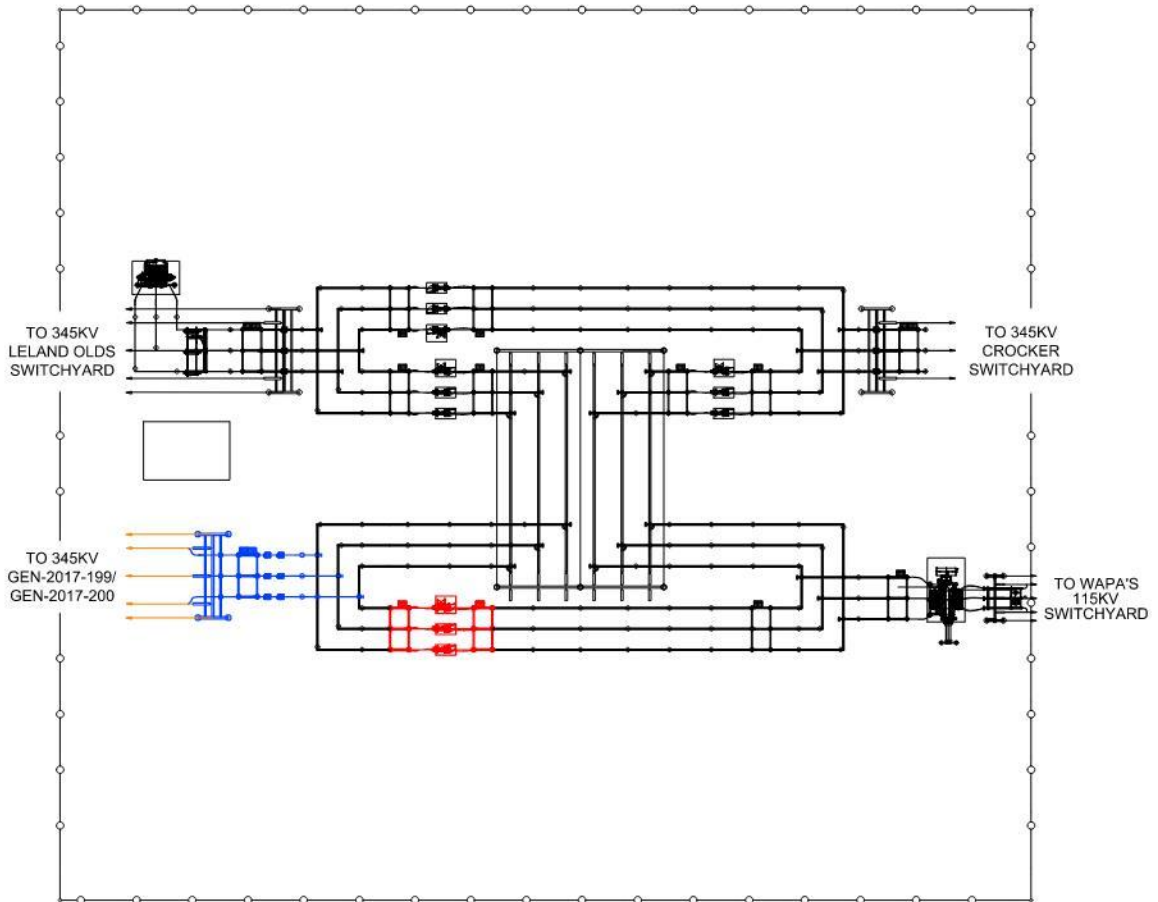

Figure A2: Proposed General Arrangement

FIGURE A2
GEN-2017-199/GEN-2017-200

LEGEND:

- EXISTING EQUIPMENT
- NON SHARED NETWORK UPGRADES
- SHARED NETWORK UPGRADES
- TRANSMISSION OWNERS INTERCONNECTION FACILITIES
- INTERCONNECTION CUSTOMER INTERCONNECTION FACILITIES
- FUTURE



ATTACHMENT A
SPP INTERCONNECTION FACILITIES STUDY REQUEST LETTER

December 29, 2022

Subject: Facilities Study Request for DISIS-2017-002

Dear Mr. Severson:

Per the Generator Interconnection Procedures (GIP), SPP requests that Basin Electric Power Cooperative (BEPC) perform facilities study in accordance with Section 8.11 for the following Interconnection and/or Network Upgrade(s):

Upgrade Type	UID	Upgrade Name	DISIS Cost Estimate	DISIS Lead Time
Current Study	156423	Groton 345-115 kV Second Transformer Build (DISIS-2017-002)	\$9,435,938.00	36
Current Study	156455	Logan 230-115 kV Transformer Replacement (DISIS-2017-002)	\$7,187,673.00	36
Interconnection	143484	Groton 345kV Interconnection Expansion (DISIS-2017-002)	\$1,497,972.00	15
Interconnection	143506	Logan 230kV Interconnection Expansion (DISIS-2017-002)	\$1,317,063.00	15
Interconnection	143507	Logan 230kV GEN-2017-214 Interconnection (TOIF) (BEPC)	\$937,785.00	15
Current Study	156415	Groton BE8 to Groton South 115 kV Second Line Build (DISIS-2017-002) (BEPC)	\$656,362.00	36
Interconnection	143485	Groton 345kV GEN-2017-199 Interconnection (TOIF) (BEPC)	\$395,733.00	15
Interconnection	143487	Groton 345kV GEN-2017-200 Interconnection (TOIF) (BEPC)	\$395,733.00	15
Interconnection	143509	Logan 230kV GEN-2017-215 Interconnection (TOIF) (BEPC)	\$50,000.00	3
Interconnection	143511	Logan 230kV GEN-2017-216 Interconnection (TOIF) (BEPC)	\$50,000.00	3
Interconnection	143547	Logan 230kV GEN-2017-235 Interconnection (TOIF) (BEPC)	\$50,000.00	3
Interconnection	143549	Logan 230kV GEN-2017-236 Interconnection (TOIF) (BEPC)	\$50,000.00	3

** If the upgrade cost studied is higher than 20% of DISIS estimates, please provide justification in the facility report.*

The scope of the Facilities Study is to determine the cost estimates of equipment, engineering, procurement, and construction as well as the associated lead times.

For the completion of this Facilities Study request, please provide a Facilities Study report to SPP within ninety (90) calendar days to include all of their Interconnection and Network Upgrade(s) listed in the



HELPING OUR MEMBERS WORK TOGETHER
TO KEEP THE LIGHTS ON... TODAY AND IN THE FUTURE

table above. Additionally, please provide an updated and completed Standardized Cost Estimate Report (SCERT) via the Transmission Reporting and Communication (TRAC) tool.

Sincerely,
SPP Generator Interconnection Department
201 Worthen Drive
Little Rock, AR 72223-4936